



Bobcat®

A300

Compact Loaders



Machine Rating

Rated operating capacity	1362 kg
Tipping load	2772 kg
Pump capacity – A300	78.4 l/min
Pump capacity – A300H	151 l/min
Steering pump	51.5 l/min
System relief at Quick Couplers	22.4–23.1 MPa
Max. travel speed — inching	6.4 km/h
Max. travel speed — low	11.1 km/h
Max. travel speed — high	19.1 km/h
Max. travel speed — reverse	11.1 km/h

Engine

Make / Model	Kubota V3800-DI-T-E3
Fuel / Cooling	Diesel / Liquid
Power	58 kW
Torque at 1500 RPM (SAE J1 995 Gross)	298 Nm
Number of cylinders	4
Displacement	3769 cm ³
Fuel tank capacity	87.1 l

Weights

Operating weight, A300	3934 kg
Operating weight, A300H	3954 kg

Controls

Vehicle steering (AWS)	Direction and speed controlled with left-hand joystick. Pattern is a C-type.
Vehicle steering (SS)	Direction and speed controlled with left-hand joystick. Pattern is an S-type.
Loader hydraulics tilt and lift	Right-hand joystick (SJC)
Front auxiliary (standard)	Electrical switches on right-hand joystick

Drive System

Transmission	Infinitely variable tandem hydrostatic piston pumps, driving two fully reversing hydrostatic motors
--------------	---

Standard Features

Two-speed travel	Hydraulic bucket positioning kit
Adjustable suspension seat	Instrumentation
Automatically activated glow-plugs	Lift arm support
Bob-Tach™ frame	Parking brake
Bobcat Interlock Control System (BICS)	Rocker-switch activated glow plugs
Deluxe operator cab	Seat belt with three-point fixing
Includes interior cab foam, top and rear windows	Seat bar
Heated enclosed cab	Turbo-charger with approved spark arrestor
Dual steering mode: All Wheel Steer (AWS) and Skid Steer (SS)	12 x 16.5, 12-ply, Bobcat heavy duty tyres
Operating lights, front and rear	CE certification

* Roll Over Protective Structure (ROPS) – meets requirements of SAE-J1040 and ISO 3471; Falling Object Protective Structure (FOPS) - meets requirements of SAE-J1043 and ISO 3449, Level I

Options

High-Flow hydraulics	12 x 16.5, 12-ply, Bobcat severe duty tyres
Power Bob-Tach™	12 x 16.5, 12-ply, Bobcat severe duty tyres, poly fill
Air conditioning	33 x 15.5-16.5, 12-ply, Bobcat superflotation tyres
Deluxe instrument panel	33 x 15.5-16.5, 12-ply, Bobcat Turf and sand tyres

Dimensions

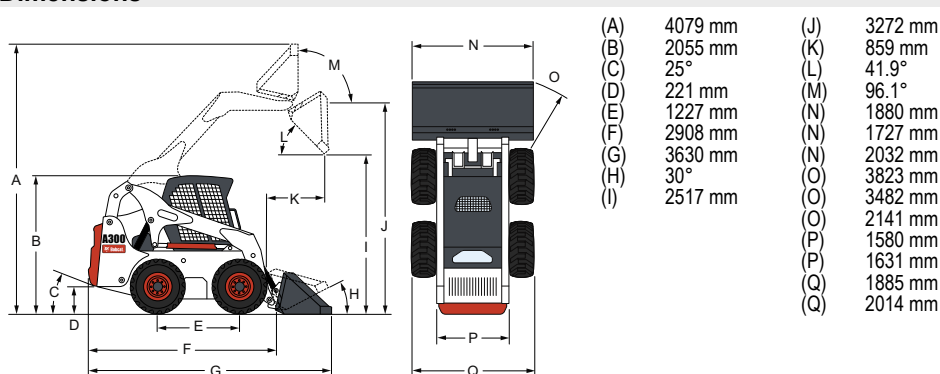

Attachments

- Angle blade
- Angle broom*†
- Auger
- Backhoe
- Box blade
- Brushcat rotary cutter
- Buckets
- Chipper*
- Combination bucket
- Concrete pump*
- Cutter crusher*
- Digger
- Dozer blade*
- Dumping hopper
- Ejector bucket
- Farm grapple
- Grader*
- Hydraulic breaker**
- Industrial grapple
- Landplane
- Landscape rake
- Mixing bucket*
- Pallet fork – standard
- Pallet fork – hydraulic
- Planer*
- Scarifier
- Snow blower*
- Sod layer*
- Soil conditioner*
- Salt and sand spreader
- Stump grinder*
- Super scraper
- Sweeper
- Three-point hitch
- Tiller
- Tilt-Tatch™
- Tree transplanter*
- Trench compactor
- Trencher
- Utility frame
- Vibratory roller
- Wheel saw
- Whisker broom

*Attachment control kit required.

**When operating the loader with this attachment, a Special Applications Kit, which includes a 12 mm Lexan front door with 6 mm top and rear windows, must be used.

†Optional water kit.



www.bobcat.eu