



**Bobcat**®

# Compact Tracked Loaders

Product Range



# More productivity, less effort

## ■ Get more done in a day

The undercarriage of our compact tracked loaders provides high pushing force and large lifting capabilities, so you can get the job done faster and with less effort.

## ■ A machine for all seasons

Rain or shine, hot or cold, mud or hard slopes – you can take it to the extreme with these machines. Each machine adapts to a large variety of applications allowing you to maximize its use.

## ■ Get a grip

Thanks to our unique high performance undercarriage, you get greater traction than from wheeled compact loaders – especially on sandy, soft, wet or sloped surfaces!



## ■ Do it right – in one go

You get all the stability and accuracy you need for an excellent job finish. Lower ground pressure means less ground disturbance and less site repair.

Plus, features like the Speed Management System give you precise control all the time.



# So easy, so comfortable and yet, so durable!

Every aspect of our compact tracked loader has been engineered to make work easy and comfortable, without compromising on the renowned durability of Bobcat machines.

## ■ Operator comfort

Enjoy a smooth ride thanks to the robust revolutionary Roller Suspension™ system. The all-steel design ensures a comfortable ride in any job site situation.



More space in sprocket area



Sloped surfaces

Clean-out holes

## ■ Take it easy

Enhance accuracy and job finishing with our Speed Management System. It allows the operator to automatically set up a constant speed.

Increase productivity using the Power Bob-Tach™ option. It enables the operator to change many attachments without getting out of the cab, so he can work faster and get more done.

Monitor the vital functions of the machine, and add another level of security with our Deluxe Instrumentation Panel. The keyless start allows the panel to be locked out to prevent unauthorized starting.

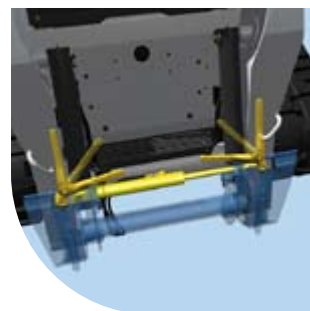

Power Bob-Tach™



SJC





# Bobcat®



**T110**



**T140**

## MACHINE RATING

Rated operating capacity (ISO 14397-1)	kg	505	642
Tipping load (ISO 14397-1)	kg	1443	1834
Pump capacity (std flow / high flow)	l/min	47.5	64
System relief at quick couplers	MPa	20.7	18.3 - 18.9
Travel speed	km/h	8.4	11.8
Ground pressure	kPa	31.7	35.8

## DIMENSIONS

Length with standard bucket	mm	2972	3153
Width over standard bucket	mm	1270	1422
Height with operator cab	mm	1882	1967
Height to bucket hinge pin	mm	2634	2783
Ground contact length	mm	1299	1230

## ENGINE

Make / Model		Kubota / V2403-M-DI-E3	Kubota V2403-M-DI-E3
Type		Naturally aspirated	Naturally aspirated
Fuel / Cooling		Diesel / Liquid	Diesel / Liquid
Maximum power at RPM (ISO 9249)	kW	31.2 (at 2200 RPM)	34.3 (at 2700 RPM)
Torque at RPM (SAE J1 995)	Nm	155.9 (at 1400 RPM)	158.6 (at 1650 RPM)
Number of cylinders / Displacement	cm <sup>3</sup>	4 / 2434	4 / 2433
Fuel tank capacity	l	45.2	50.4

## WEIGHTS

Operating weight*	kg	2379	3021
Shipping weight	kg	2100	2697

## TRACTION

Standard tracks	mm	250	300
-----------------	----	-----	-----

## CONTROL OPTIONS

Bobcat Std (foot pedals / steering levers)		Std	Std
Advanced Hand Controls (AHC)		-	Opt
Advanced Control System (ACS)		-	Opt
Selectable Joystick Controls (SJC)		-	Opt

## FACTORY OPTIONS

High Flow hydraulics		-	-
Cab enclosure with heating		Opt	Opt
Cab enclosure with heating and air conditioning		-	-
Deluxe instrument panel		Opt	Opt
Power Bob-Tach™		Opt	Opt
Roller Suspension™		-	-
Steel tracks		-	-

(\*) Base machine with bucket, fuel tank full and operator.



**T190 / T190H**



**T250 / T250H**



**T300 / T300 H**



**T320 / T320 H**

1088	1168	1461	1461
3108	3338	4177	4177
61.6 / 96.4	80.2 / 151	80.2 / 151	80.2 / 151
22.4 - 23.1	22.4 - 23.1	22.4 - 23.1	22.4-23.1 / 24.6-25.3
11.7	10.6	10.6	10.6
33.8	28	29	27

3309	3630	3630	3630
1727	2032	2032	2032
1938	2055	2055	2055
3002	3109	3201	3261
1401	1618	1618	1618

Kubota V2607-DI-TE3B-BC-1	Kubota V3800-DI-T-E3	Kubota V3800-DI-T-E3	Kubota V3800-DI-T-BOBCAT
Turbo	Turbo	Turbo	Turbo
Diesel / Liquid	Diesel / Liquid	Diesel / Liquid	Diesel / Liquid
45.5 (at 2700 RPM)	58 (at 2400 RPM)	58 (at 2400 RPM)	67.6 (at 2400 RPM)
218 (at 1425 RPM)	298 (at 1500 RPM)	298 (at 1500 RPM)	315 (at 1600 RPM)
4 / 2600	4 / 3769	4 / 3769	4 / 3769
106	98.4	98.4	98.4

3453 / 3473	4240 / 4260	4401 / 4421	4401 / 4421
3081	3804	3961	3961

320	450	450	450
-----	-----	-----	-----

Std	Std	Std	Std
Opt	Opt	Opt	Opt
Opt	Opt	Opt	Opt
Opt	Opt	Opt	Opt

Opt	Opt	Opt	Opt
Opt	Opt	Opt	Opt
Opt	Opt	Opt	Opt
Opt	Opt	Opt	Opt
Opt	Opt	Opt	Opt
Opt	Opt	Opt	Opt
-	Opt	Opt	Opt

# No time for downtime

## ■ Built for durability

Tough environments can damage critical components and affect the performance, productivity and lifetime of your machine. To safeguard your investment, we use top quality components only, and keep all vital components away from harm through innovative design features. The result is a tough, durable workhorse that just keeps on going!

## ■ Value that lasts

This durability and serviceability also ensure that your Bobcat compact tracked loader retains its residual value!

- A robust, full-length belly pan provides extra protection to the drivetrain, engine, hydraulics and hydrostatic system
- A completely closed, heavy-duty one-piece tailgate protects the engine compartment
- E-coat painting that resists chipping and corrosion
- Direct belt drive reduces engine wear and fuel consumption
- Rollers made of Austempered Ductile Iron (ADI), fully sealed and lubricated for life
- The Bridgestone C-pattern tracks feature steel imbeds that guide and support centre of the track
- Dual path cooling system.



## ■ Steel tracks

### Bobcat introduces the first all-steel track option for compact tracked loaders

It offers a 40% increase in pushing force, driving up productivity by moving more material in less time. When you're working in earthmoving, or in abrasive or extremely wet conditions, the steel track undercarriage offers you greater traction.



Roller



Belt drive



Cooling system



Tail gate



## ■ Easy maintenance, less downtime

Minimizing downtime gives you the edge when it comes to productivity. We've made it easy for you to reach all the essential machine parts.



# Versatility taken to the limit

## ■ Take on any challenge

Bobcat compact tracked loaders are not just loaders, they are tool carriers too. Our optional high flow hydraulics enhance the capabilities and performance of your attachments.

## ■ A machine for every application

The widest choice of attachments in the industry allows your Bobcat compact tracked loader to work in several applications. From landscaping, forestry and grading applications to agriculture and asphalt jobs.

All Bobcat attachments are tested by our engineers for optimum performance and safety approval.



	T110	T140	T190	T250	T300	T320
<b>ATTACHMENTS</b>						
Angle Broom	X	X	X	X	X	X
Auger	X	X	X	X	X	X
Backhoe	X	X	X	X	X	X
Bale Fork	X	X	X	X	X	X
Box Blade		X	X			
Brushcat™ Rotary Cutter		X	X	X	X	X
Brush Saw <small>(currently for non-CE countries only)</small>		X	X	X	X	X
Bucket, Construction	X	X	X	X	X	X
Bucket, Dirt				X	X	X
Bucket, Feeding		X	X			
Bucket, Fertilizer		X	X			
Bucket, Low Profile	X	X	X			
Bucket, Snow		X	X	X	X	X
Combination Bucket		X	X	X	X	X
Concrete Pump			X	X	X	X
Cutter Crusher		X	X			
Digger	X	X	X			
Dozer Blade		X	X	X	X	X
Drop Hammer			X	X	X	X
Dumping Hopper	X	X	X	X	X	X
Flail Cutter		X	X	X	X	X
Forestry Cutter				X	X	X
Forks, Utility	X	X	X			
Grader		X	X			
Grapple, Farm/Utility	X	X	X			
Grapple, Industrial		X	X	X	X	X
Hydraulic Breaker	X	X	X	X	X	X
Landplane	X	X	X	X	X	X
Landscape Rake		X	X	X	X	X

	T110	T140	T190	T250	T300	T320
<b>ATTACHMENTS</b>						
Mixing Bucket			X	X	X	X
Mower	X	X	X			
Pallet Forks, Standard	X	X	X	X	X	X
Pallet Forks, Hydraulic		X	X	X	X	X
Planer		X	X	X	X	X
Salt and Sand Spreader		X	X	X	X	X
Scarifier	X	X	X			
Scraper	X	X	X	X	X	X
Snow Blade	X					
Snow V-blade	X	X	X	X	X	X
Snowblower	X	X	X	X	X	X
Sod Layer		X	X	X	X	X
Soil Conditioner	X	X	X	X	X	X
Stabilizers, Rear		X	X	X	X	X
Stump Grinder		X	X	X	X	X
Sweeper	X	X	X	X	X	X
Three-Point Hitch Adapter	X	X	X	X	X	X
Tiller	X	X	X	X	X	X
Tilt-Tatch		X	X			
Tree Transplanter		X	X	X	X	X
Trench Compactor		X	X	X	X	X
Trencher	X	X	X	X	X	X
Utility Frame	X	X	X	X	X	X
Vibratory Roller		X	X	X	X	X
Water Kit		X	X	X	X	X
Wheel Saw			X	X	X	X
Whisker Broom		X	X			
Wood Chipper			X	X	X	X

Specifications and design are subject to change without notice. - Pictures of Bobcat products may show other than standard equipment.



www.bobcat.eu



**Bobcat**®

